

# COOK CONCRETE PRODUCTS, INC.

—Precast—



MANHOLE PIPE • DRAINAGE INLETS • STORM WATER/OIL INTERCEPTORS • UTILITY VAULTS & BOXES • CUSTOM PRECAST

(530) 243-2562  
FAX (530) 243-6881  
www.cookconcreteproducts.com  
e-mail:  
Info@cookconcreteproducts.com

5461 EASTSIDE ROAD  
P.O. BOX 720280  
REDDING, CA 96099

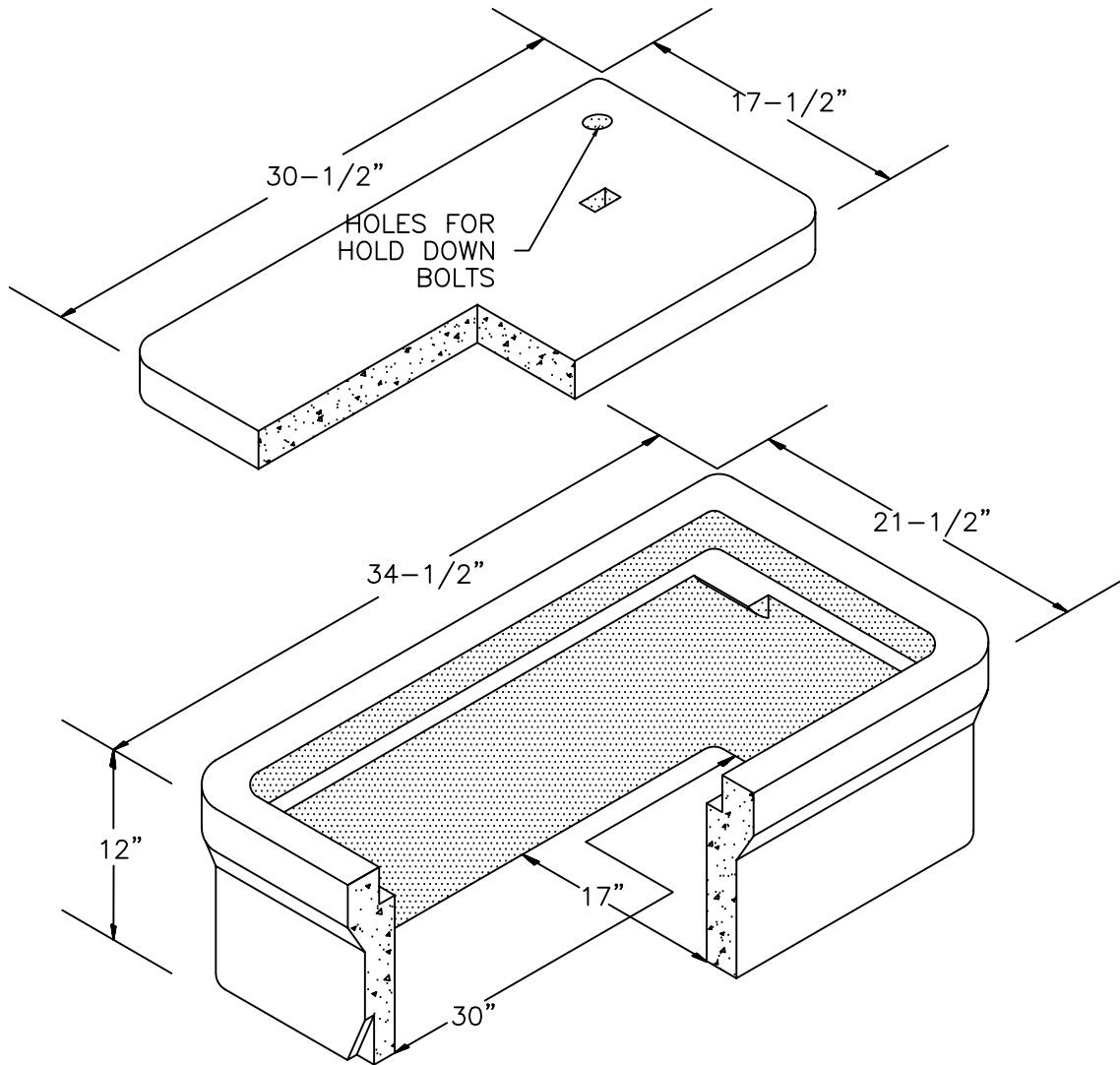

#### LIDS AVAILABLE:

1. CONCRETE
2. CONCRETE W/HINGED READING LID
3. STEEL— LIGHT TRAFFIC
4. AVAILABLE WITH OR WITHOUT HOLD DOWN BOLTS
5. H10 LOADING (10,400 LBS. OVER 10" X 10" AREA)
6. APPROVED BY C.O.R FOR ELECTRIC

#### NOTES:

1. BOX WEIGHT: 130#
2. EXTENSION WEIGHT: 125#
3. CONCRETE LID WEIGHT: 86#
4. STEEL LID WEIGHT: 72#

**#2.0 BOX**