

MANHOLE PIPE • DRAINAGE INLETS • STORM WATER/OIL INTERCEPTORS • UTILITY VAULTS & BOXES • CUSTOM PRECAST

(530) 243-2562
FAX (530) 243-6881
www.cookconcreteproducts.com
e-mail:
Info@cookconcreteproducts.com

5461 EASTSIDE ROAD
P.O. BOX 720280
REDDING, CA 96099

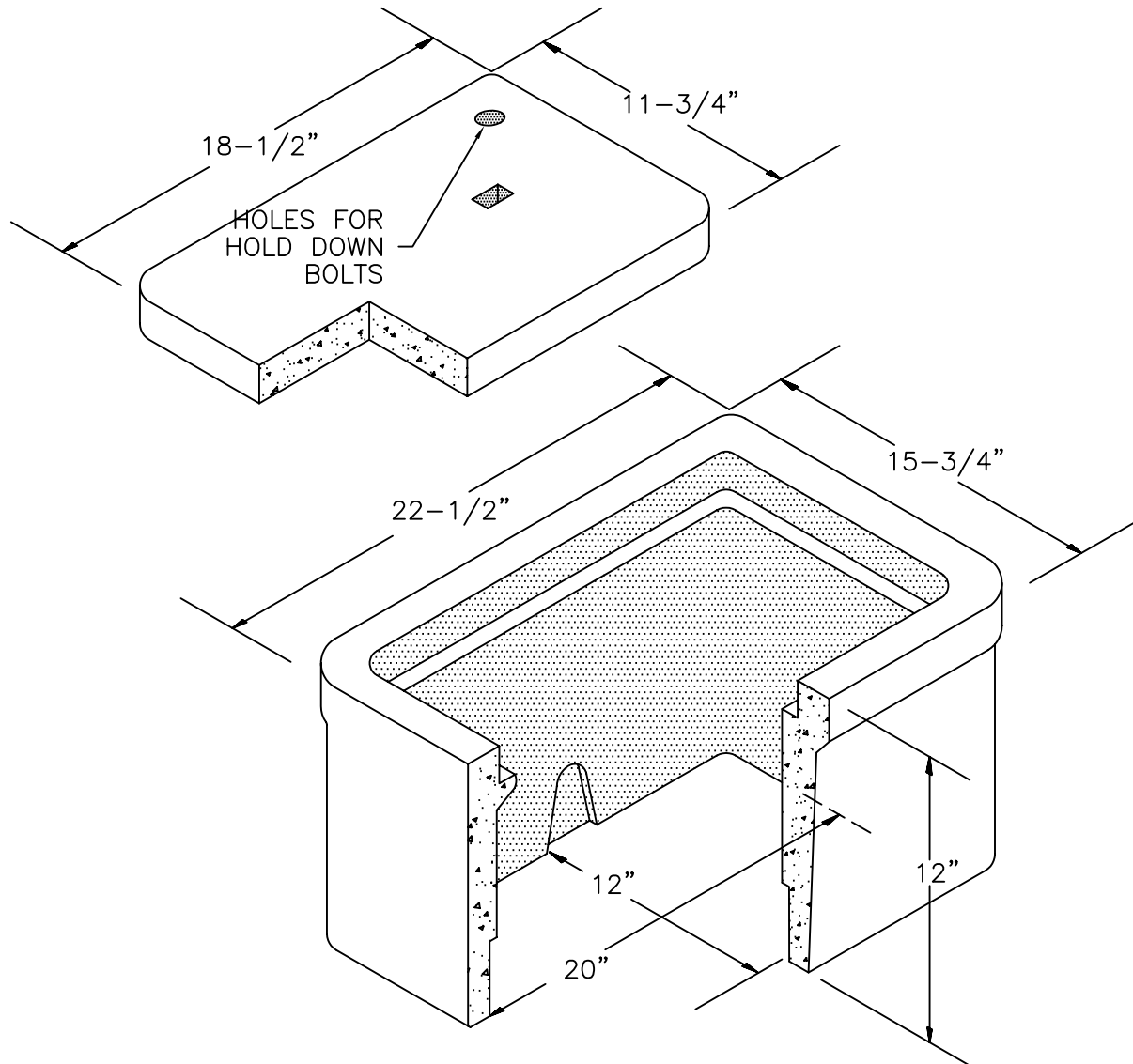

LIDS AVAILABLE:

1. CONCRETE
2. CONCRETE W/HINGED READING LID
3. STEEL— LIGHT TRAFFIC
4. AVAILABLE WITH OR WITHOUT HOLD DOWN BOLTS

NOTES:

1. BOX WEIGHT: 79#
2. EXTENSION WEIGHT: 78#
3. CONCRETE LID WEIGHT: 33#
4. STEEL LID WEIGHT: 32#

1.0 BOX